

F10 - 6 x 500 mL Carbon Fiber Centrifuge Rotor		
RPM	MAX RCF	k factor
10,000	17696	2533
9,500	15971	2807
9,000	14334	3127
8,500	12785	3506
8,000	11325	3958
7,500	9954	4503
7,000	8671	5169
6,500	7477	5995
6,000	6371	7036
5,500	5353	8374
5,000	4424	10132
4,500	3583	12509
4,000	2831	15831
3,500	2168	20678
3,000	1593	28145
2,500	1106	40528
2,000	708	63326
1,500	398	112579
1,000	177	253303
500	44	1013212

422 Aldo Avenue, Santa Clara, CA. 95054-2301  
 800.784.3843 - Fax 408.988.1196  
[www.piramoon.com](http://www.piramoon.com)

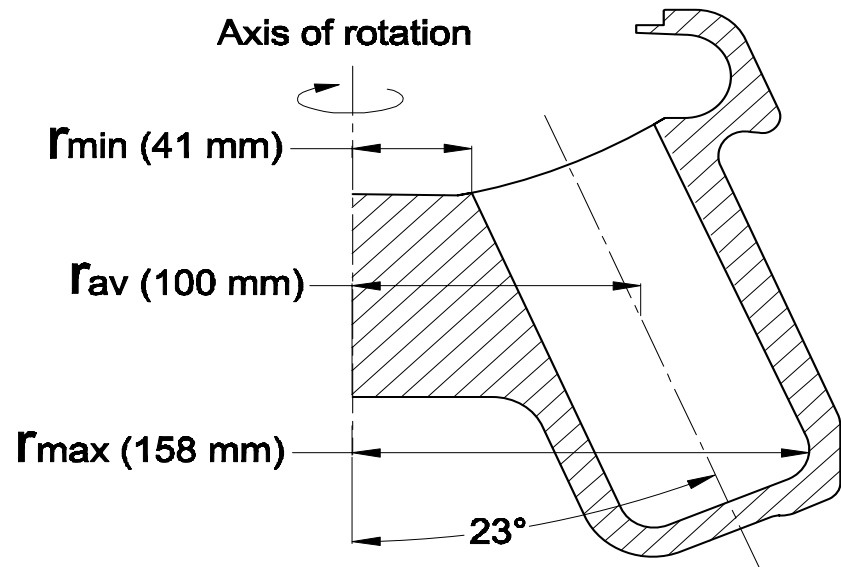

- Limited Lifetime Warranty!
- Corrosion free
- Up to 60% lighter than metallic equivalents
- Highly resistant to radiolabel contamination
- Compatible with all popular floor model centrifuges.
- No need for derating after years of use
- Fully autoclavable
- Superior insulating properties, making chilling unnecessary
- Competitively priced at or below the cost of conventional metallic rotors

Offering the rewards of 40 years of aerospace R&D to scientists and researchers everywhere. Not only is carbon fiber at the cutting edge of technology, it is also the most sensible and safe alternative to the standard aluminum and titanium alloys used to