

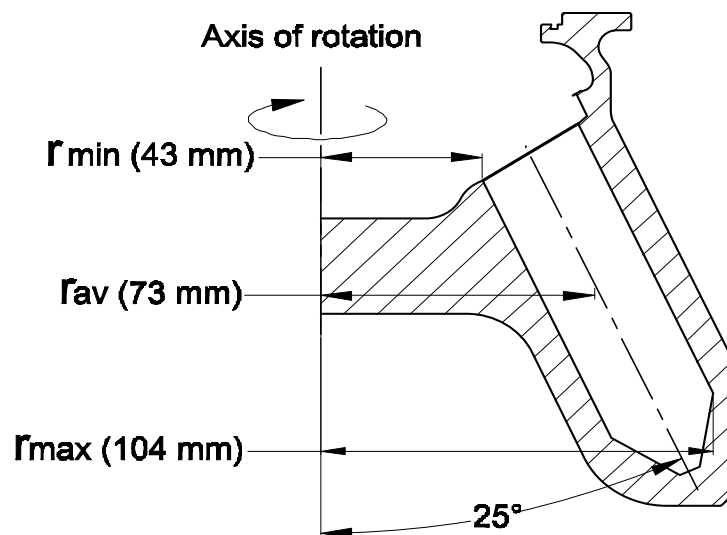

F15 - 8 x 50c mL		
Carbon Fiber Centrifuge Rotor		
RPM	MAX RCF	k factor
15000	26208	1126
14500	24490	1205
14000	22830	1292
13500	21228	1390
13000	19685	1499
12500	18200	1621
12000	16773	1759
11500	15404	1915
11000	14094	2093
10500	12842	2298
10000	11648	2533
9500	10512	2807
9000	9435	3127
8500	8416	3506
8000	7455	3958
7500	6552	4503
7000	5708	5169
6500	4921	5995
6000	4193	7036
5500	3524	8374
5000	2912	10132
4500	2359	12509
4000	1864	15831
3500	1427	20678
3000	1048	28145
2500	728	40528
2000	466	63326
1500	262	112579
1000	116	253303
500	29	1013211

422 Aldo Avenue, Santa Clara, CA. 95054-2301  
 800.784.3843 - Fax 408.988.1196  
[www.piramoon.com](http://www.piramoon.com)



- Limited Lifetime Warranty!
- Corrosion free
- Up to 60% lighter than metallic equivalents
- Highly resistant to radiolabel contamination
- Compatible with all popular floor model centrifuges.
- No need for derating after years of use
- Fully autoclavable
- Superior insulating properties, making chilling unnecessary
- Competitively priced at or below the cost of conventional metallic rotors

Offering the rewards of 40 years of aerospace R&D to scientists and researchers everywhere. Not only is carbon fiber at the cutting edge of technology, it is also the most sensible and safe alternative to the standard aluminum and titanium alloys used today for all centrifugation rotors. With properties matching those of steel, but without the negative attributes, carbon fiber is leagues ahead of metal in regards to strength, weight, and malleability. Please contact FIBERLite for further product information.