

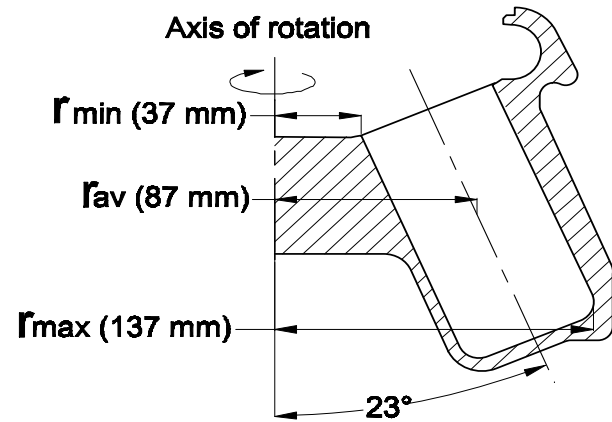

F6 - 6 x 250 mL		
Carbon Fiber Centrifuge Rotor		
RPM	MAX RCF	k factor
6000	5524	7036
5750	5073	7661
5500	4642	8374
5250	4229	9190
5000	3836	10132
4750	3462	11227
4500	3107	12509
4250	2772	14024
4000	2455	15831
3750	2158	18013
3500	1880	20678
3250	1621	23981
3000	1381	28145
2750	1160	33495
2500	959	40528
2250	777	50035
2000	614	63326
1750	470	82711
1500	345	112579
1250	240	162114

422 Aldo Avenue, Santa Clara, CA. 95054-2301  
 800.784.3843 - Fax 408.988.1196  
[www.piramoon.com](http://www.piramoon.com)



- Limited Lifetime Warranty!
- Corrosion free
- Up to 60% lighter than metallic equivalents
- Highly resistant to radiolabel contamination
- Compatible with all popular floor model centrifuges.
- No need for derating after years of use
- Fully autoclavable
- Superior insulating properties, making chilling unnecessary
- Competitively priced at or below the cost of conventional metallic rotors

Offering the rewards of 40 years of aerospace R&D to scientists and researchers everywhere. Not only is carbon fiber at the cutting edge of technology, it is also the most sensible and safe alternative to the standard aluminum and titanium alloys used today for all centrifugation rotors. With properties matching those of steel, but without the negative attributes, carbon fiber is leagues ahead of metal in regards to strength, weight, and malleability. Please contact FIBERLite for further product information.